



DAHL 140-50 Hand Primer Kit

To be used with Model 65, 75 & 100 Diesel Fuel Filter/Water Separators

PRIMER INSTALLATION

1. Cut the hose at a convenient location a few inches from the inlet port (as shown in illustration).
2. Install the hand primer in the line.
3. Tighten the clamps securely.

ELIMINATION OF AIR

1. Pump the primer bulb until it is firm.

DRAINING WATER

NOTE: The bowl should always be drained before water or contaminant levels reach the bottom of the depressurizer cone. Check daily with the engine off. Always open the draincock or remove the pipe plug completely to flush particulates out. Failure to do so could cause a leaky valve.

DAHL Primer Assembly Detail

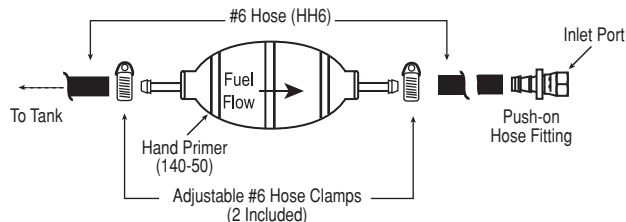

DAHL Mounting Assembly Detail

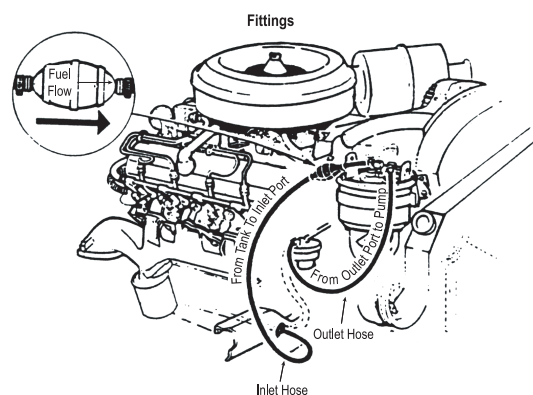
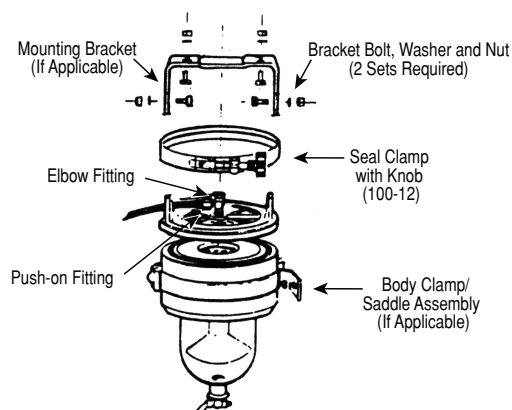

DRAINING WATER CONT'D.

A. DAHL Units Mounted HIGHER Than Fuel Storage Tank

1. Turn engine off. Vent the DAHL filter to allow draining.
2. Loosen the outlet fitting compression nut and then the draincock or remove the pipe plug. Open the draincock and squeeze the primer bulb to evacuate all contaminants.
3. Close the draincock or replace the pipe plug and follow the priming instructions shown below.

B. DAHL Units Mounted LOWER Than Fuel Storage Tank

1. Turn engine off and close shut-off valve. (Valved Manifold units may be drained and elements replaced with the engine running at idle. Close the inlet and outlet valves to isolate the filter being serviced.)
2. Open the draincock or remove the pipe plug completely and drain all contaminants.
3. Close the draincock or replace the pipe plug and follow the priming instructions shown below.

ELEMENT REPLACEMENT

A. When To Replace

As a general guideline, depending on fuel quality and engine use, elements should be replaced as follows:

1. DAHL 101 is a 2 micron element which can be used approximately 500 hours or 20,000 miles. (DAHL 101-W is a 10 micron element for use in winter or severe applications and DAHL 101-30 is a 30 micron element.)
2. If you have a vacuum gauge, the first replacement should be made at the very first indication of power loss at high RPMs. Make a note of the vacuum gauge reading at this point. The differences in various fuel system requirements make it impossible to predict what this reading will be. Mark the reading on the gauge dial or the unit for future element replacement.

B. How To Replace Contaminated Element

1. Open the draincock or remove the pipe plug completely to empty the bowl and flush particulates out. Failure to do so could cause a leaky valve.
2. Loosen, but don't remove, the lid clamp knob. Support the filter body with your hand prior to release.
3. Remove the element with a turning motion. At this point, you may clean the outside of the filter body. Use only clean diesel fuel or kerosene and wipe clean.
4. Check the centerpipe O-Ring and replace if hard or damaged.
5. Remove and replace the lid gasket. Be sure the lid groove and body lip are clean. (Grease the lid cover gasket before positioning.)

C. Reassembly

1. Lubricate the top and bottom element gaskets. Install the element onto the centerpipe with a turning motion.
2. Fill the filter body with clean diesel fuel to within one inch of the top.
3. Double check the lid cover gasket position in the lid groove.
4. Attach the body to the lid and hand tighten the lid clamp knob. Check the circumference of the body and lid for proper clamp alignment. (See "up" arrows on band for correct orientation.)

D. Priming

1. Eliminate the air by loosening the swivel fitting on the outlet port and squeezing the bulb repeatedly until the diesel fuel appears at the swivel. Then tighten the swivel fitting.
2. Start engine and check for leaks.

NOTE: For any marine or other unit utilizing the heat deflector shield, clean the shield to remove any accumulated diesel fuel.

DAHL Products Division

BALDWIN FILTERS

a CLARCOR company

4400 East Highway 30 • P.O. Box 6010
Kearney, Nebraska 68848-6010
Phone: (308) 234-1951 • Toll Free: (800) 822-5394
Fax: (800) 828-4453 • Int'l Fax: (308) 237-9769
Internet: www.baldwinfilter.com